

# BRAND GUIDELINES

# CONTENTS

About Us	<b>03</b>
Brand Mission	<b>04</b>
Brand Vision	<b>05</b>
Brand Values	<b>06</b>
Logo Design	<b>07</b>
Colors	<b>24</b>
Typography	<b>33</b>
Layout Grid	<b>43</b>
CTA Buttons	<b>49</b>
Imagery	<b>53</b>
Essentials	<b>57</b>

# ABOUT US

## Built for Publishers. Engineered for Profit.

Bidmatic is a U.S.-based adtech company focused on helping publishers maximize ad monetization. We provide advanced advertising technology, expert strategy, and hands-on support to boost revenue and simplify operations. Our platform also uses AI to support content creation and improve overall performance, helping publishers grow smarter and faster.

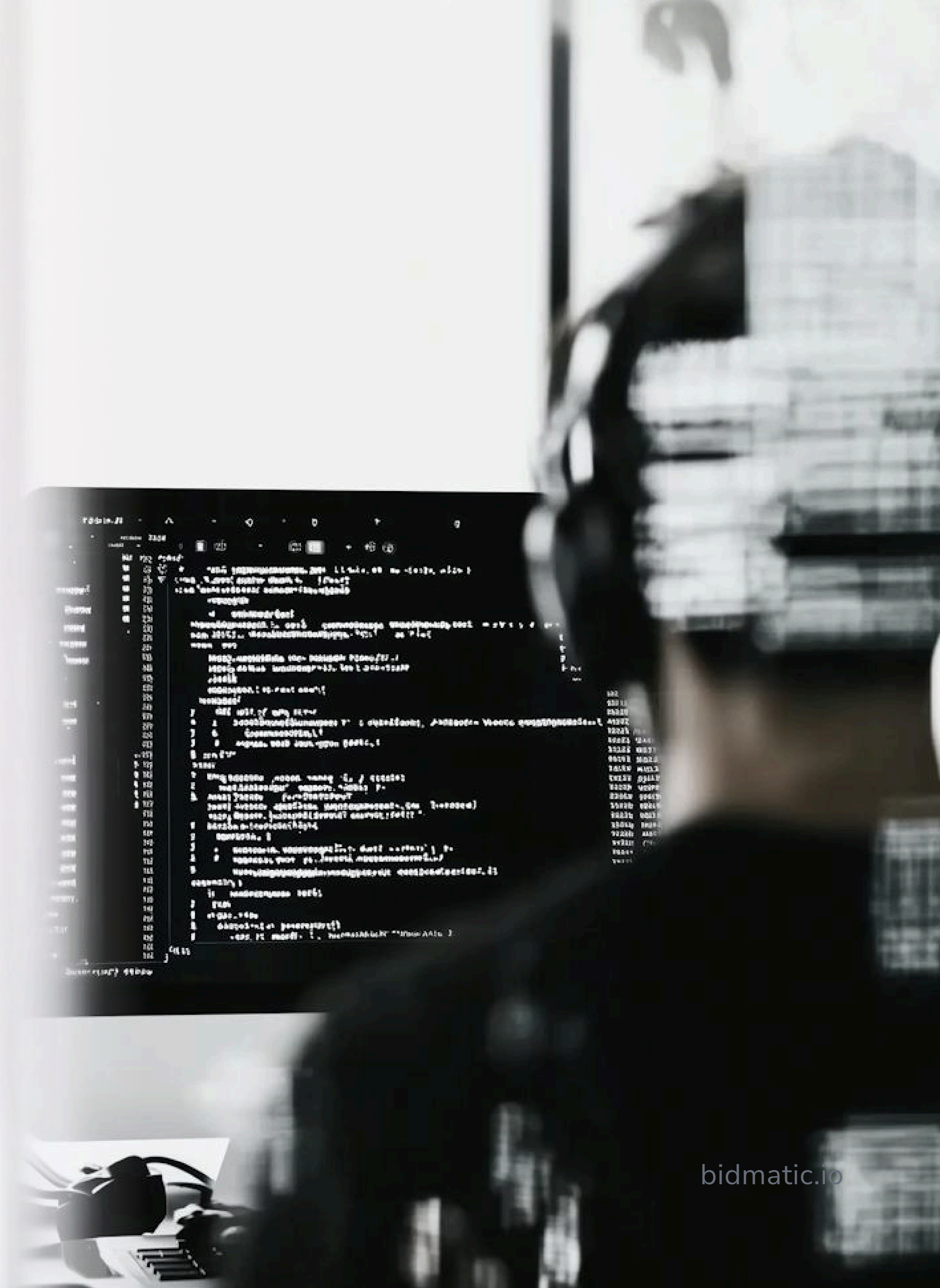

# BRAND MISSION

Bidmatic.io is committed to helping publishers maximize value from every site visitor, delivering safe ads that protect user experience, and offering advertisers a competitive space to meet and surpass their goals. We also deliver content solutions that boost engagement and sustain growth over time.

# BRAND VISION

To empower publishers, users, and advertisers with transparent, safe, and effective digital experiences that create real value for everyone.

# BRAND VALUES

---

## **Intelligence Over Hype**

In a trend-driven tech culture, we prioritize lasting ideas and thoughtful actions. We blend knowledge with experience to create enduring strategies. True innovation relies on careful planning and commitment.

---

## **Proactive Curiosity**

Our approach is to pursue answers with a curious and proactive mindset. This fosters innovation, allowing us to address client needs before problems arise and promoting a culture of initiative and continuous learning.

---

## **Clarity Is Our Currency**

We embrace curiosity and action. Our proactive mindset drives innovation and helps us identify opportunities early. This approach ensures evolving solutions for clients and fosters a culture of continuous learning for our team. We thrive at the intersection of "why" and "why not."

---

## **Care Is the Competitive Edge**

We make the complex simple. Whether optimizing ad spend or building algorithms, clarity is essential. We avoid jargon and inflated metrics, believing that true intelligence is transparent and empowering. Our clients always understand what's working and what's next. With clarity integrated into our system, decisions are faster and performance improves.

# Logo Design



**bidmatic.io**

# LOGOMARK

**b**

“B” is for “bid”

+

**m**

“M” is for “matic”

+

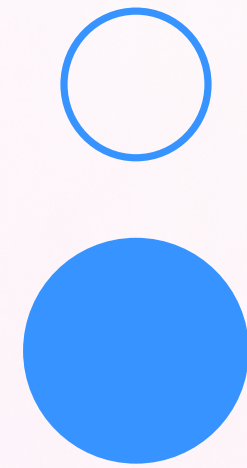

circles from “.io”

=



# EMBLEM

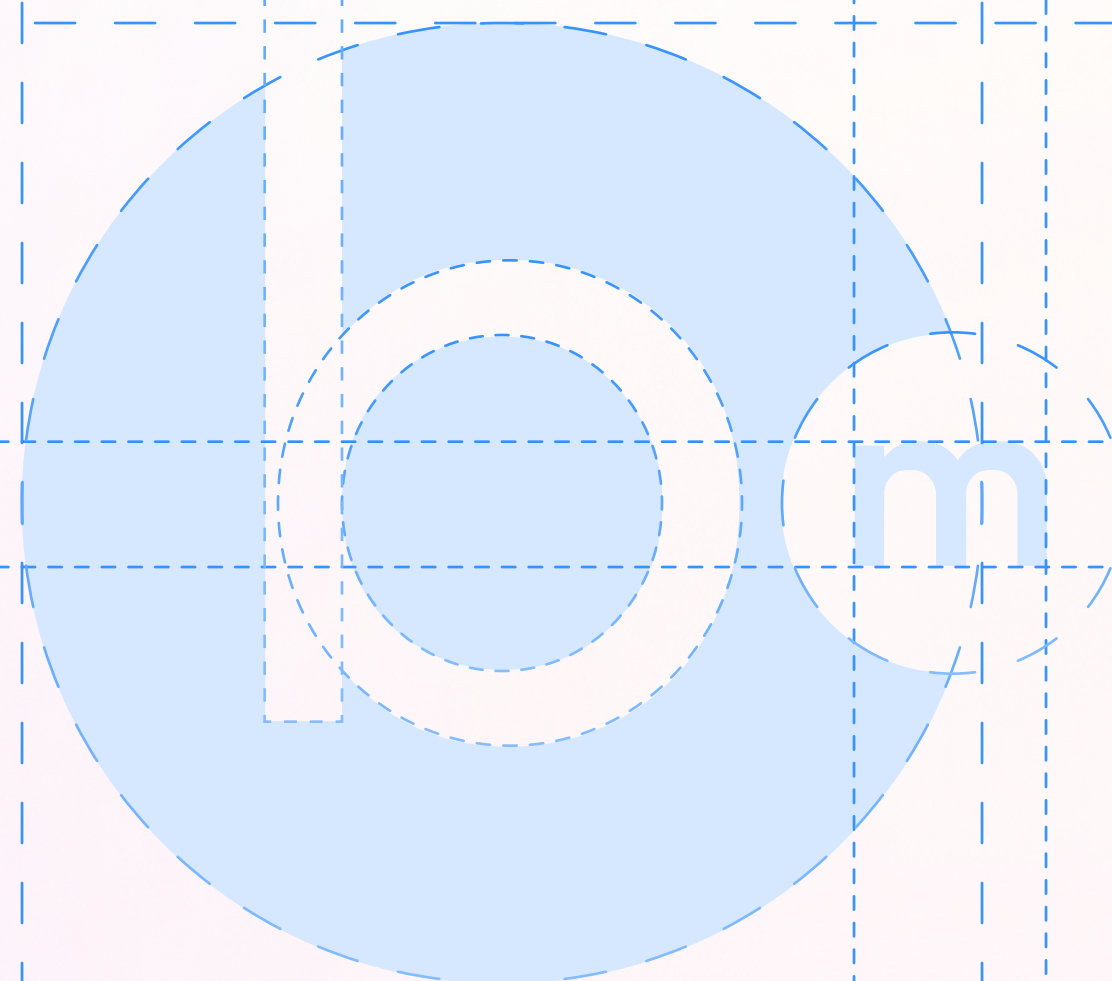

# LOGOTYPE

In our logo typography we used Gilroy & Poppins font mix.

Our standard logo includes differentiation the “.io” part with color, the same way as the emblem.

**bidmatic.io**

# CLEAR SPACE



# MINIMUM SIZES

The logo can be scaled up as large as you need, but it must never be used smaller than recommended minimums as shown.



16px



32px



180px



192px



512px

# MINIMUM SIZES



<b>Usage</b>	desktop
<b>Width</b>	240
<b>Height</b>	50



<b>Usage</b>	mobile
<b>Width</b>	180
<b>Height</b>	37

# COLOR COMBINATIONS

Light Mode



Light Mode (Dev Stage)



Dark Mode



Dark Mode (Dev Stage)





# PLACEMENT

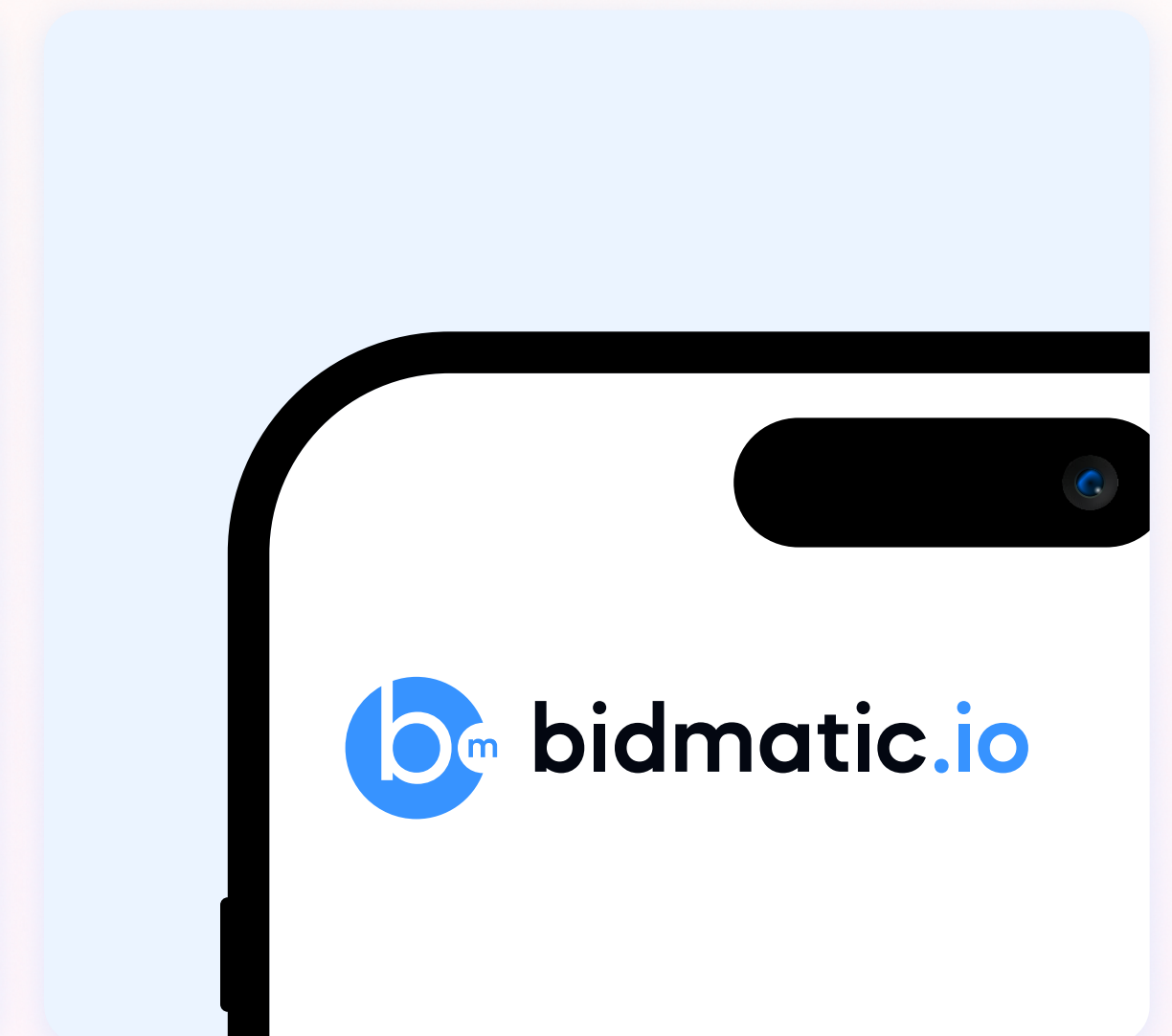
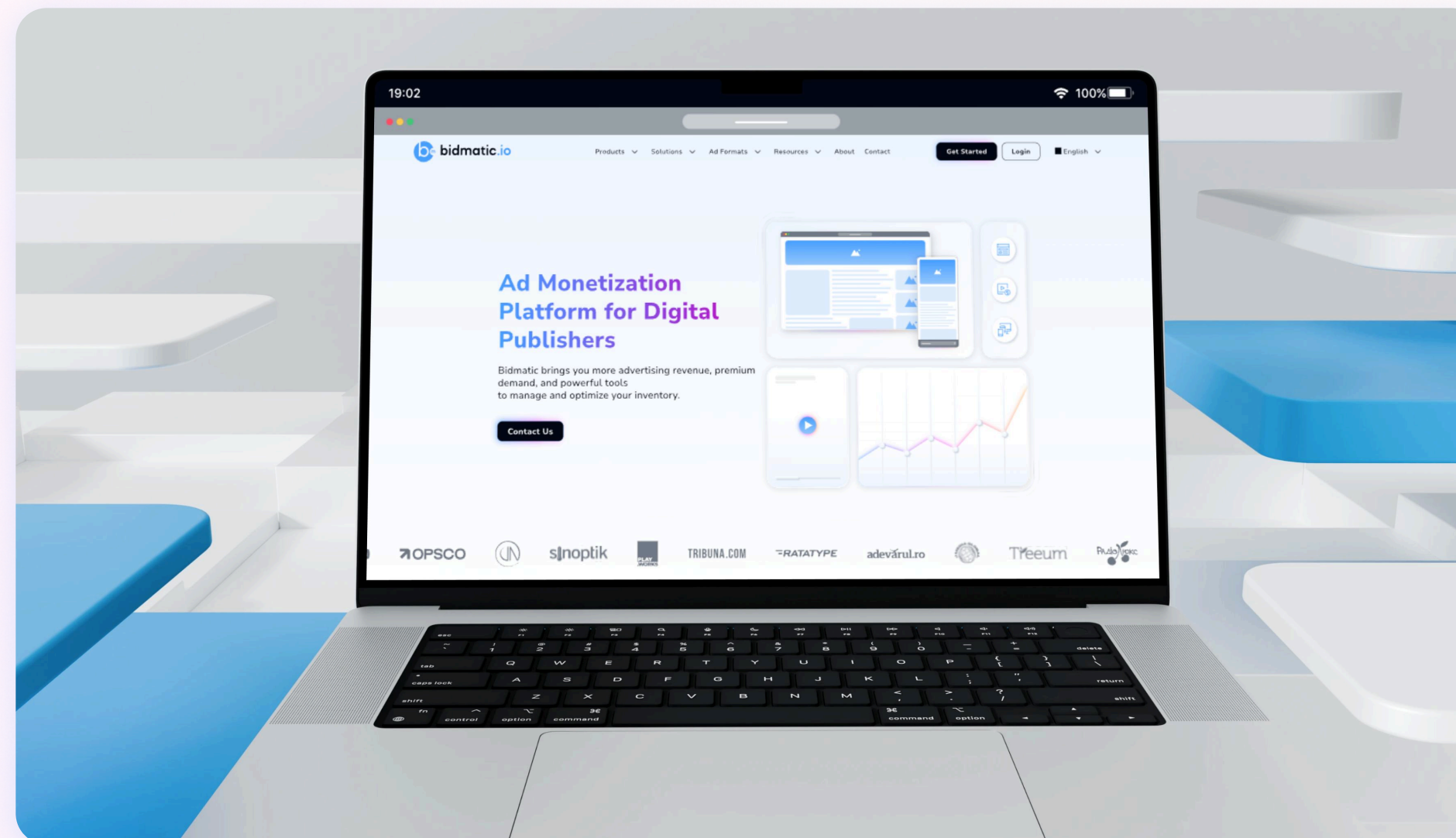
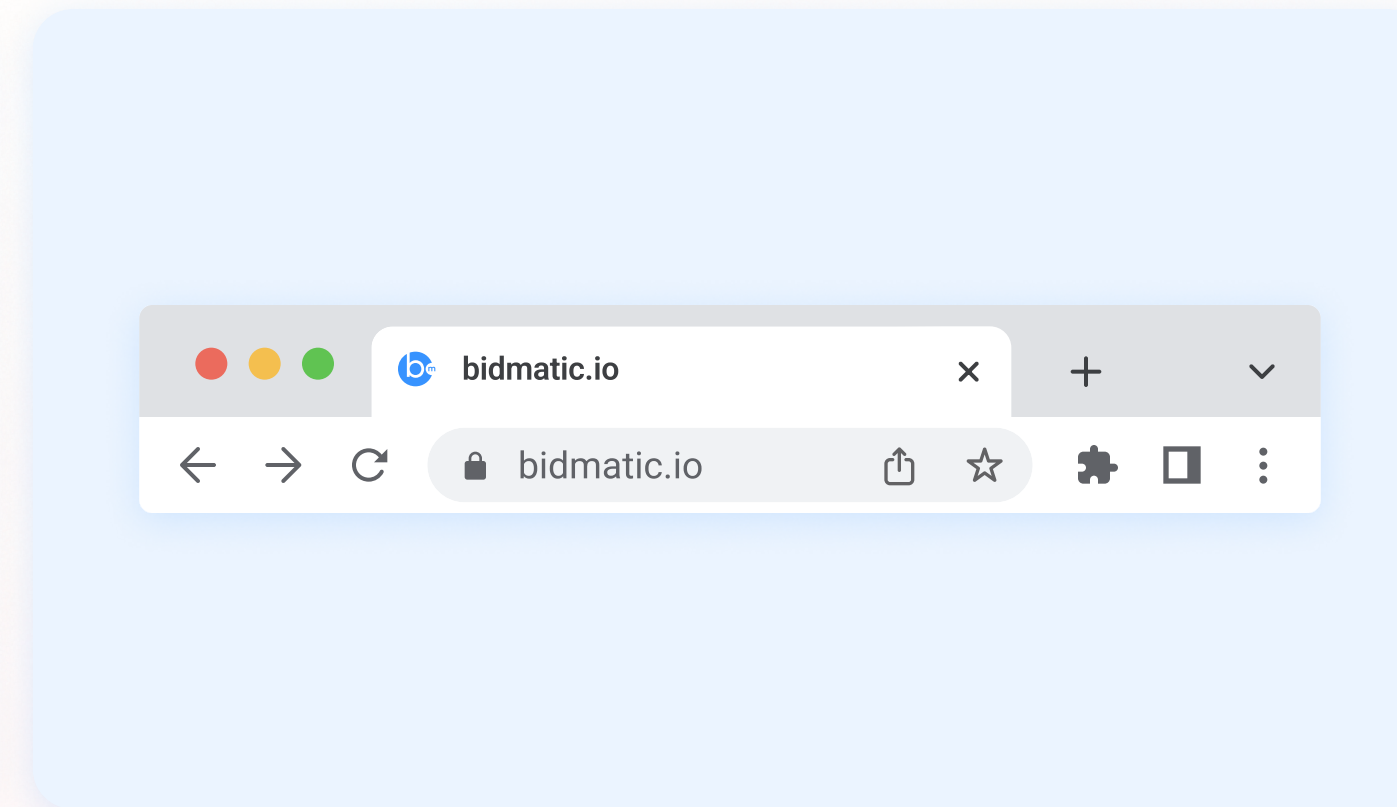

# HeroVideo



herovideo

# LOGOMARK

h

“H” is for “hero”

+

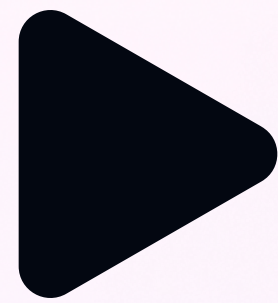

“▶” is for “video”

+

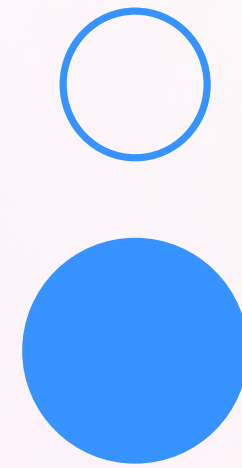

circles from “.io”

=



# EMBLEM

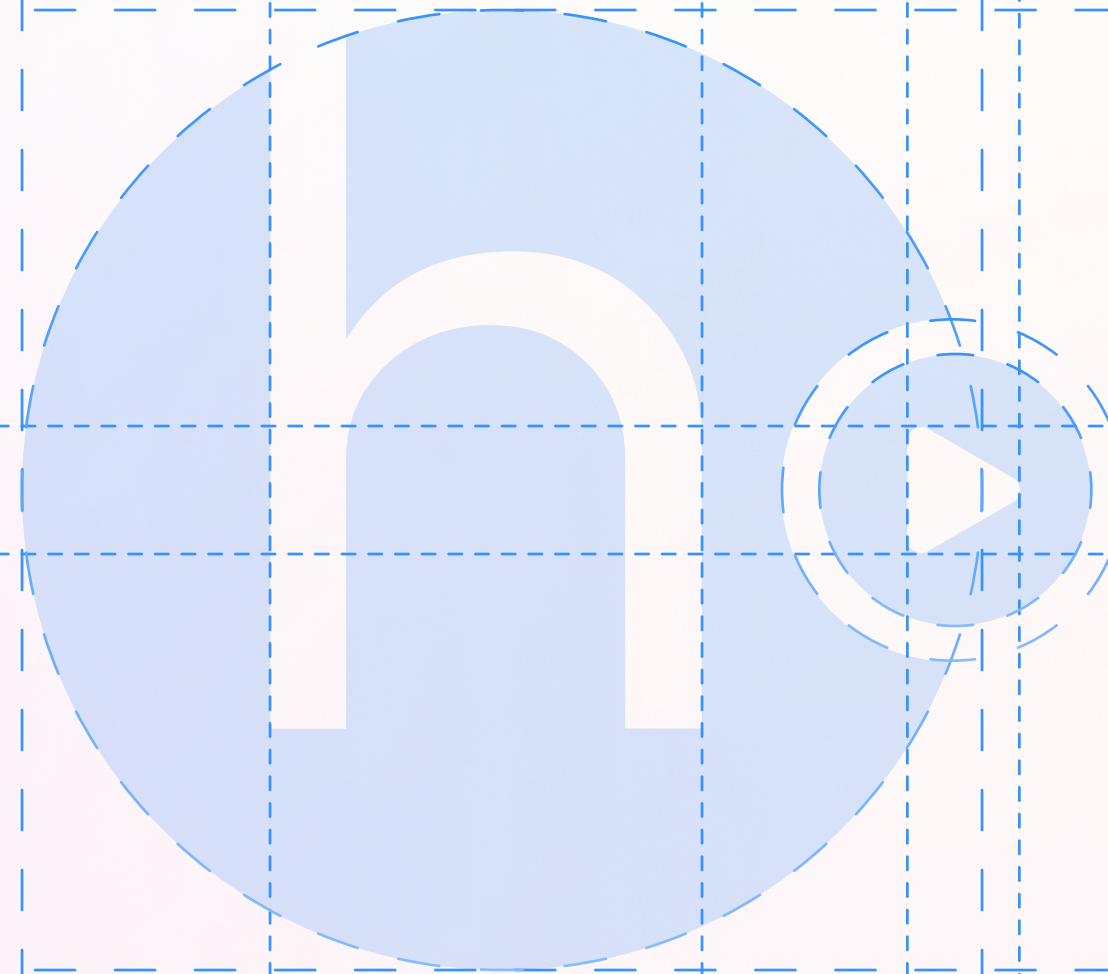

# LOGOTYPE

In HeroVideo logo typography we used Gilroy & Poppins font mix.

Our standard logo includes differentiation the “video” word with color, the same way as the emblem.

herovideo

# CLEAR SPACE



# Colors

# DIGITAL PALETTE OVERVIEW

## Primary Colors

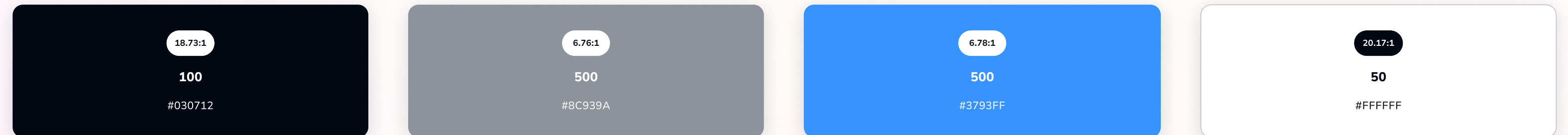

## Secondary Colors

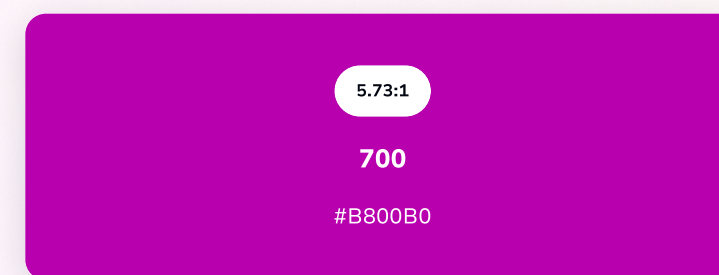

## Caution Colors



# BASE COLOR PALETTE

Base colors form the foundation of your design, setting the overall mood and theme. They are typically used for backgrounds and large areas to create a cohesive look.

**HEX:** FFFFFFFF  
**RGB:** 255, 255, 255  
**CMYK:** 0, 0, 0, 0  
**Pantone:** —

20.17:1

50

#FFFFFF

**HEX:** 030712  
**RGB:** 3, 7, 18  
**CMYK:** 0, 0, 0, 100  
**Pantone:** 6 C

20.17:1

50

#FFFFFF

# NEUTRAL (GRAY) COLOR PALETTE

Neutral colors offer a subtle and sophisticated backdrop, complementing other hues without overwhelming them. They are ideal for creating balance and visual rest in a design.

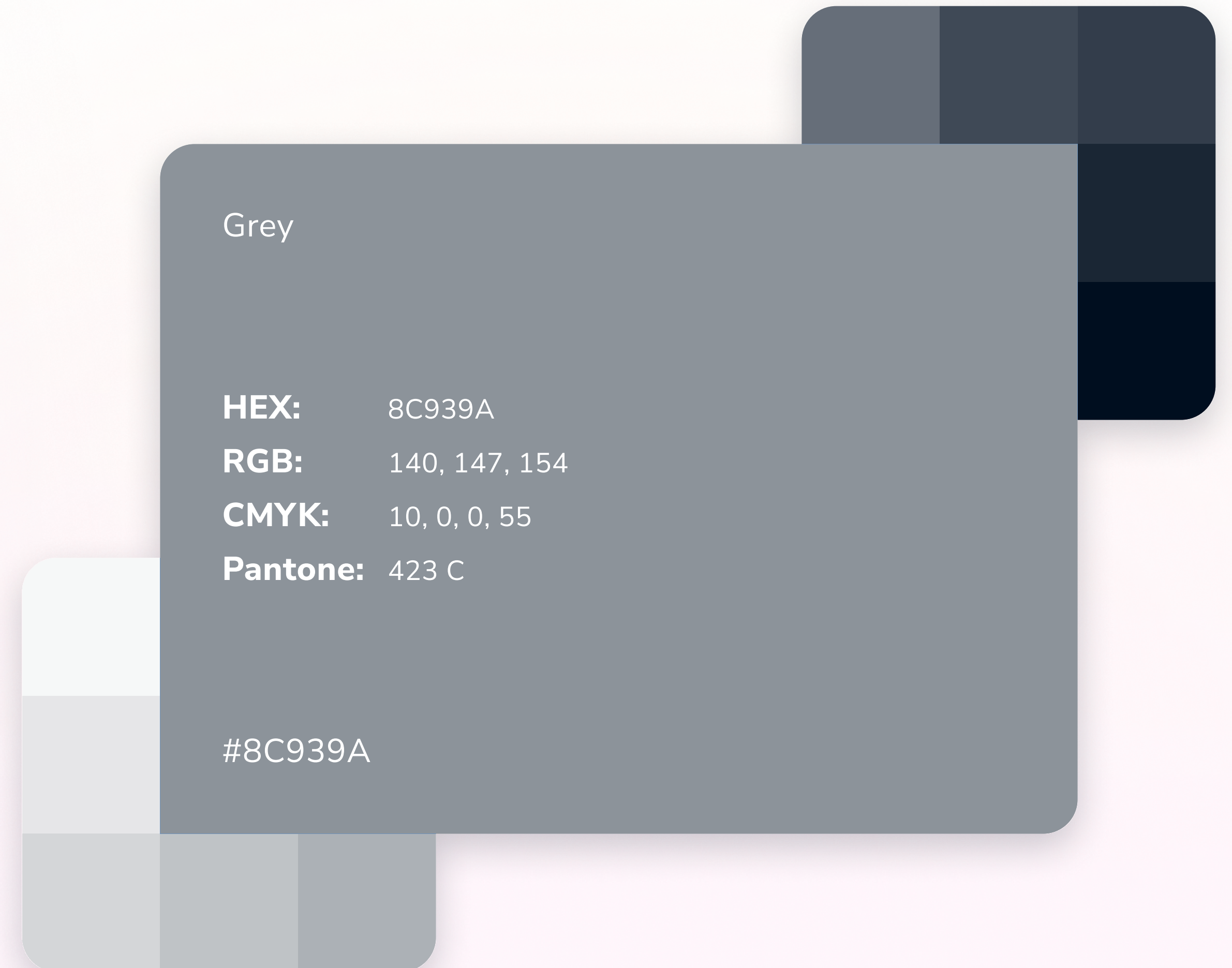

# PRIMARY COLOR PALETTE

Primary colors are bold and eye-catching, perfect for drawing attention and making a strong visual statement. They are often used to highlight key elements and call-to-actions in a design.

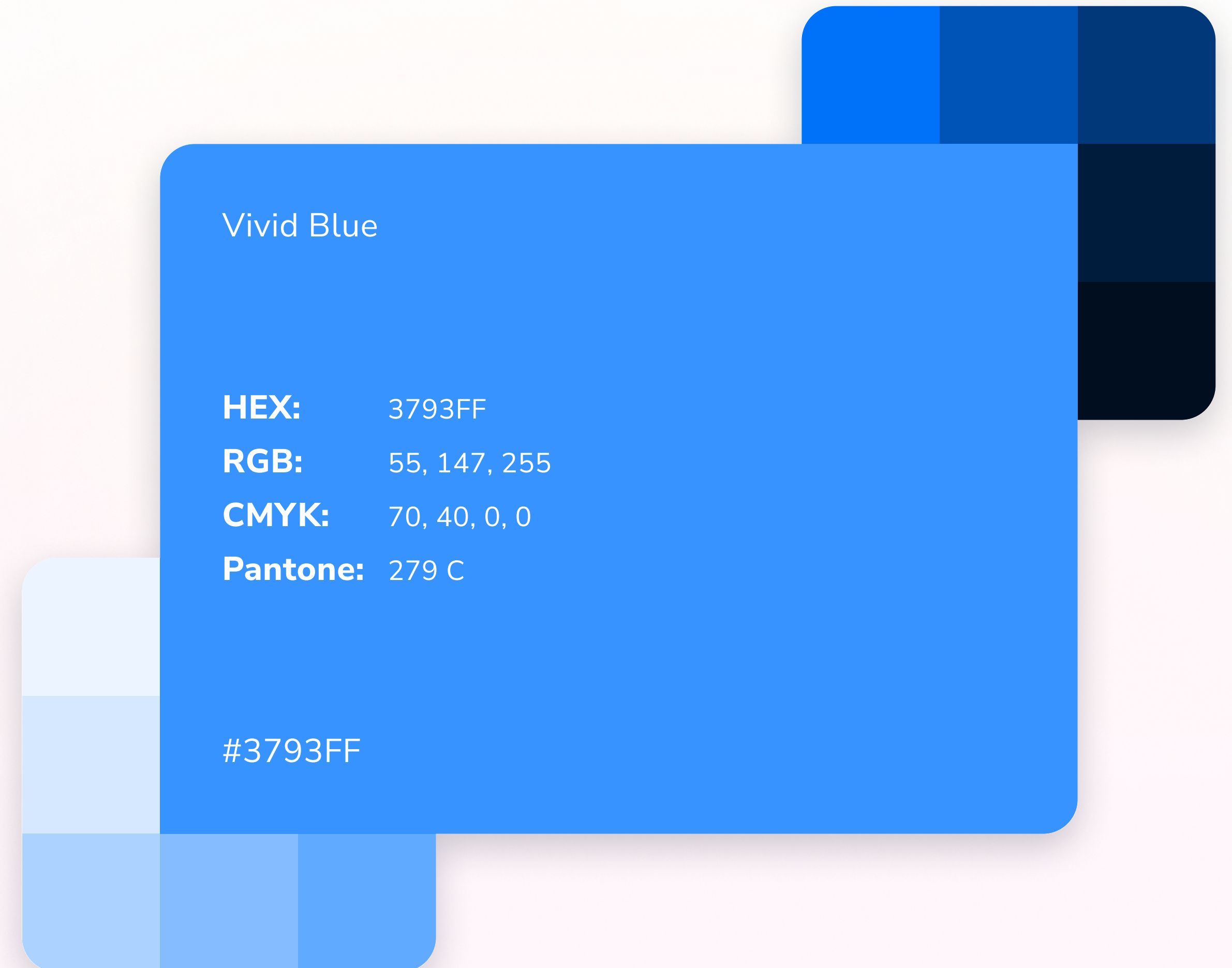

# TERTIARY COLOR PALETTE

Tertiary colors bring depth and complexity, adding nuance and refinement to your palette. They work well for detailed elements and subtle gradients.



# NEGATIVE COLOR PALETTE

Negative colors typically signify caution or restraint, conveying a sense of seriousness or formality. They are often used in designs where a sober or professional tone is required.

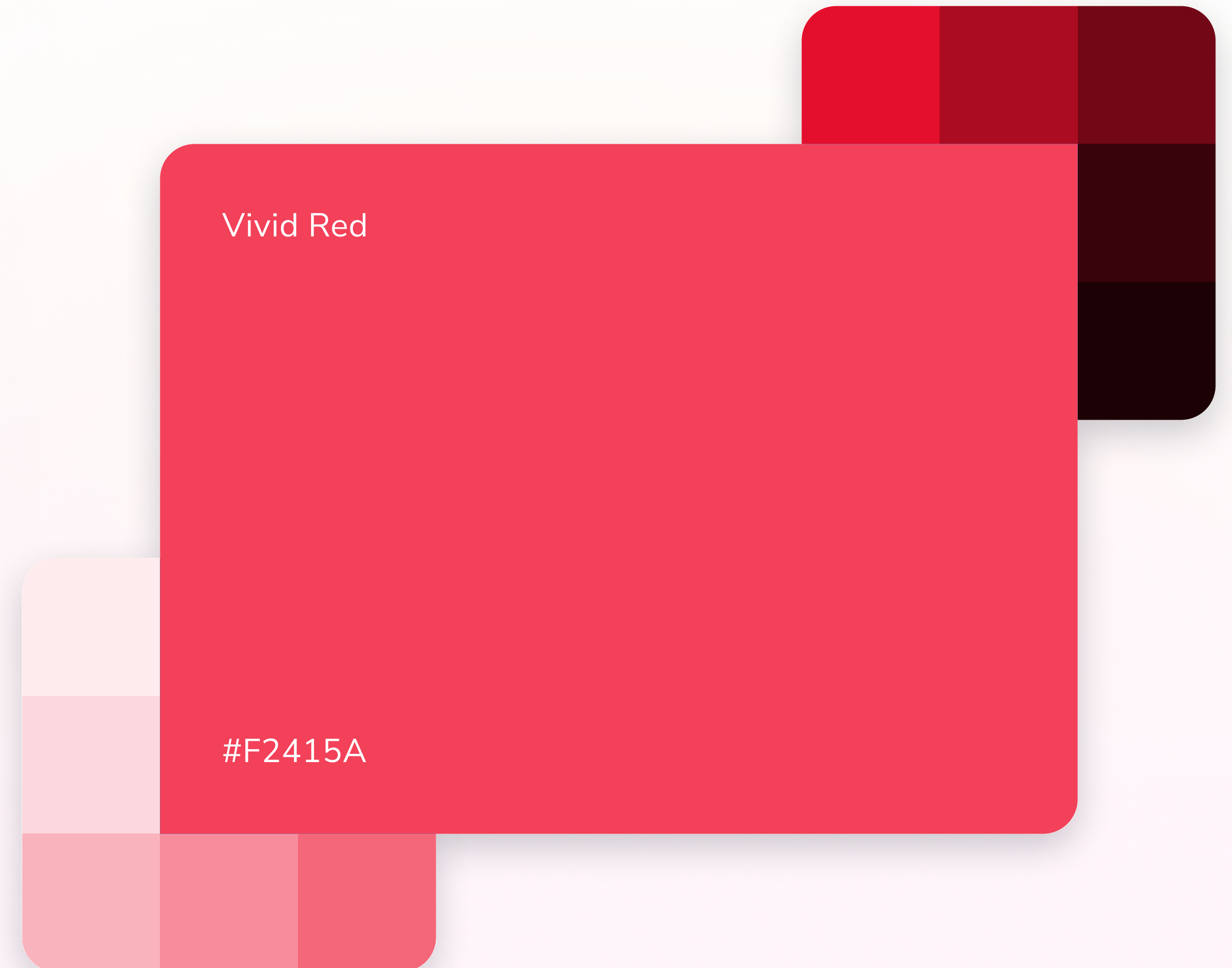

# WARNING COLOR PALETTE

Warning colors are designed to grab attention quickly and convey urgency or importance. They are most effective for alerts, error messages, or important notices in a design.



# GRADIENTS

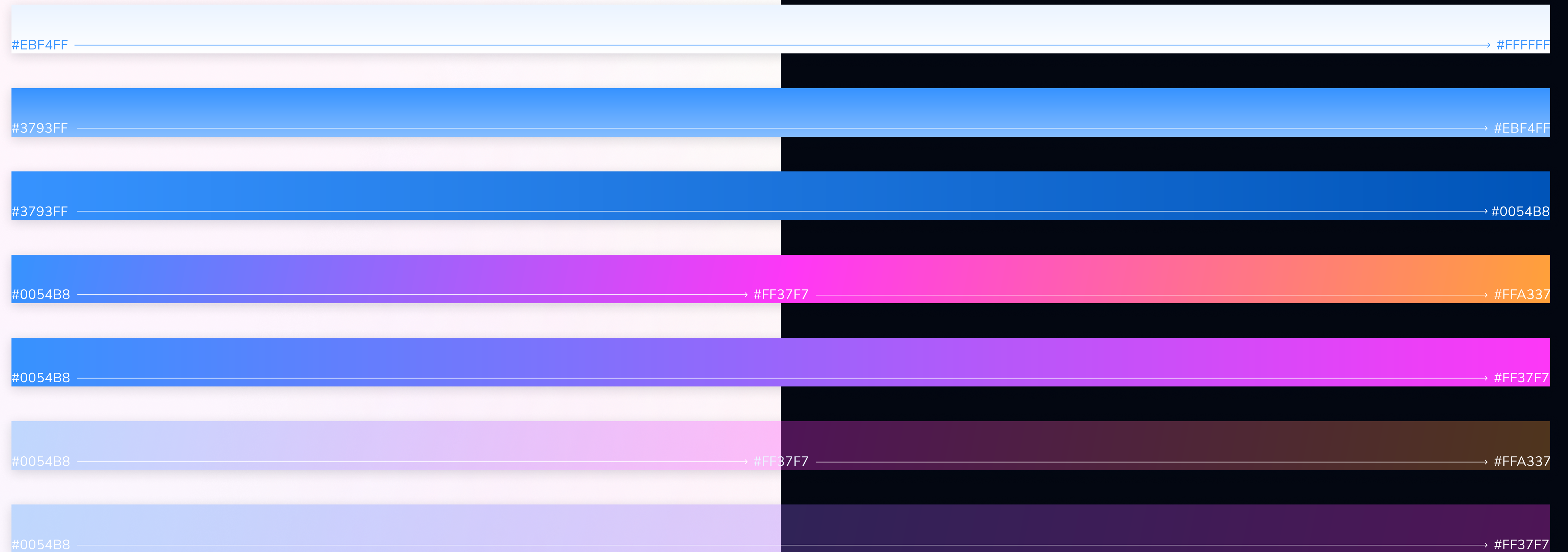

# Typography

# TYPEFACE

**NUUNITO**

**Extrabold**

**SANS**

**Bold**

Regular

# TYPEFACE

Aa

Aa, Bb, Cc, Dd, Ee, Ff, Gg,  
Hh, Ii, Jj, Kk, Ll, Mm, Nn,  
Oo, Pp, Qq, Rr, Ss, Tt, Uu,  
Vv, Ww, Xx, Yy, Zz

0123456789  
!@#\$%^&\*?

# DESKTOP TYPE SCALING - HEADER

**H1 Example. The quick brown fox jumps...**

Nunito Sans ExtraBold  
Size is 56 px  
Line spacing is 120% (67.2 px)



**H2 Example. The quick brown fox jumps over the lazy...**

Nunito Sans ExtraBold  
Size is 42 px  
Line spacing is 120% (50.4 px)



**H3 Example. The quick brown fox jumps over the lazy dog**

Nunito Sans ExtraBold  
Size is 32 px  
Line spacing is 120% (38.4 px)



**H4 Example. The quick brown fox jumps over the lazy dog**

Nunito Sans ExtraBold  
Size is 24 px  
Line spacing is 120% (28.8 px)



H5 Example. The quick brown fox jumps over the lazy dog

Nunito Sans Regular  
Size is 24 px  
Line spacing is 120% (28.8 px)



H6 Example. The quick brown fox jumps over the lazy dog

Nunito Sans ExtraBold  
Size is 20 px  
Line spacing is 120% (24 px)



# DESKTOP TYPE SCALING - BODY TEXT

**Body 1 Example. The quick brown fox jumps over the lazy dog**

Nunito Sans Bold  
Size is 20 px  
Line spacing is 120% (24 px)



Body 1 Example. The quick brown fox jumps over the lazy dog

Nunito Sans Regular  
Size is 20 px  
Line spacing is 120% (24 px)



[Body Text 1 \(Links\) Example. The quick brown fox jumps over the lazy dog](#)

Nunito Sans Regular  
Size is 20 px  
Line spacing is 120% (24 px)



**Body Text 2 Example. The quick brown fox jumps over the lazy dog**

Nunito Sans Bold  
Size is 16 px  
Line spacing is 120% (19.2 px)



Body Text 2 Example. The quick brown fox jumps over the lazy dog

Nunito Sans Regular  
Size is 16 px  
Line spacing is 120% (19.2 px)



[Body Text 2 \(Links\) Example. The quick brown fox jumps over the lazy dog](#)

Nunito Sans Regular  
Size is 16 px  
Line spacing is 120% (19.2 px)



# MOBILE TYPE SCALING - HEADER

**H1 Example. The quick brown fox jumps over the lazy dog**

Nunito Sans ExtraBold  
Size is 32 px  
Line spacing is 120% (38.4 px)



**H2 Example. The quick brown fox jumps over the lazy dog**

Nunito Sans ExtraBold  
Size is 24 px  
Line spacing is 120% (28.8 px)



**H3 Example. The quick brown fox jumps over the lazy dog**

Nunito Sans ExtraBold  
Size is 20 px  
Line spacing is 120% (24 px)



**H4 Example. The quick brown fox jumps over the lazy dog**

Nunito Sans ExtraBold  
Size is 18 px  
Line spacing is 120% (21.6 px)



H5 Example. The quick brown fox jumps over the lazy dog

Nunito Sans Regular  
Size is 18 px  
Line spacing is 120% (21.6 px)



# MOBILE TYPE SCALING - BODY TEXT

**Body 1 Example. The quick brown fox jumps over the lazy dog**

Nunito Sans Bold  
Size is 16 px  
Line spacing is 120% (16.8 px)



Body 1 Example. The quick brown fox jumps over the lazy dog

Nunito Sans Regular  
Size is 16 px  
Line spacing is 120% (16.8 px)



[Body 3 \(Links\) Example. The quick brown fox jumps over the lazy dog](#)

Nunito Sans Regular  
Size is 16 px  
Line spacing is 120% (16.8 px)



This style is used on mobile devices when it is necessary to place a lot of technical information in limited formats (for example, tables)

Nunito Sans Regular  
Size is 12 px  
Line spacing is 120% (14.4 px)



**This style is used on mobile devices when it is necessary to place a lot of technical information in limited formats (for example, tables)**

Nunito Sans Bold  
Size is 12 px  
Line spacing is 120% (14.4 px)



[Body 3 \(Links\) Example. The quick brown fox jumps over the lazy dog](#)

Nunito Sans Regular  
Size is 12 px  
Line spacing is 120% (14.4 px)



# BLOG TYPE SCALING

**H1 Example. The quick brown fox jumps over the lazy dog**

Nunito Sans ExtraBold  
Size is 40 px,  
line spacing is 120% (48 px)



**H2 Example. The quick brown fox jumps over the lazy dog**

Nunito Sans ExtraBold  
Size is 32 px,  
line spacing is 120% (38.4 px)



**H3 Example. The quick brown fox jumps over the lazy dog**

Nunito Sans Bold  
Size is 24 px,  
line spacing is 120% (28.8 px)



**H4 EXAMPLE. THE QUICK BROWN FOX JUMPS OVER THE LAZY DOG**

Nunito Sans Bold  
Size is 18 px,  
line spacing is 120% (21.6 px)



H5 EXAMPLE. THE QUICK BROWN FOX JUMPS OVER THE LAZY DOG

Nunito Sans Light  
Size is 18 px,  
line spacing is 120% (21.6 px)



Body Regular Example. The quick brown fox jumps over the lazy dog

Nunito Sans Regular  
Size is 16 pt,  
line spacing 135% (21.6 px)



**Body Bold Example. The quick brown fox jumps over the lazy dog**

Nunito Sans Bold  
Size is 16 pt,  
line spacing 135% (21.6 px)



*Body Italic Example. The quick brown fox jumps over the lazy dog*

Nunito Sans Italic  
Size is 16 pt,  
line spacing 135% (21.6 px)



Example of image description

Nunito Sans Italic  
Size is 16 pt,  
line spacing 135% (21.6 px)



Body Underlined Example. The quick brown fox jumps over the lazy dog

Nunito Sans Regular  
Size is 16 pt,  
line spacing 135% (21.6 px)



Body Link Example. [www.Quick.brown.fox/jumps/overthelazydog](http://www.Quick.brown.fox/jumps/overthelazydog)

Nunito Sans Regular  
Size is 16 pt,  
line spacing 135% (21.6 px)



Body Highlighted Example. **The quick brown fox jumps over the lazy dog**

Nunito Sans Regular  
Size is 16 pt,  
line spacing 135% (21.6 px)



Subscript and Superscript Examples. C<sub>2</sub>H<sub>6</sub>O also has a 2<sup>nd</sup> spelling - C<sub>2</sub>H<sub>5</sub>OH

Nunito Sans Regular  
Size is 16 pt,  
line spacing 135% (21.6 px)



Body Strikethrough Example. ~~The quick brown fox jumps over the lazy dog~~

Nunito Sans Regular  
Size is 16 pt,  
line spacing 135% (21.6 px)



UPPERCASE EXAMPLE. THE QUICK BROWN FOX JUMPS OVER THE LAZY DOG

lowercase example. the quick brown fox jumps over the lazy dog

Nunito Sans Regular  
Size is 16 pt,  
line spacing 135% (21.6 px)



## SECONDARY TYPEFACE

**MONTSERRAT**

Light

Regular

Medium

**Bold**

**Extrabold**

# Layout Grid

# GRID SYSTEM

When creating designs, we make four main layout sizes for different devices.

These are the dimensions and description of the layout's mesh

- Small - frame 360 px wide
- Medium - frame 768 pixels wide
- Large - frame 1024\* px wide
- Extra large - frame 1920 px wide

\*As you may see, in some points in the table the width is slightly less than the width of the frame recommended for design. This is due to the fact that we draw layouts for the most common our customer's devices in order to optimize them in the best way for popular devices

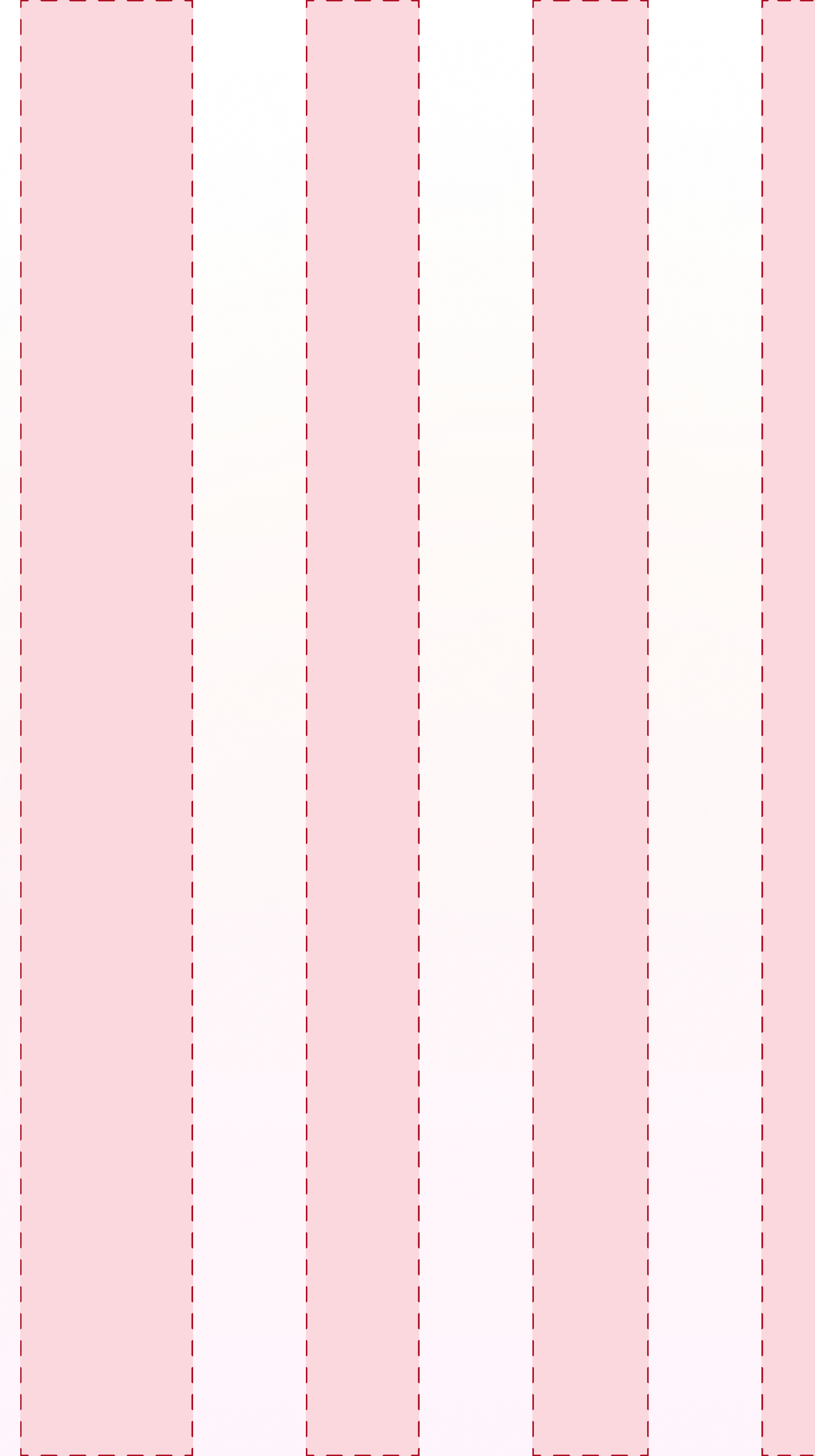

# SMALL GRID

Type: Columns  
Count: 2  
Type: Stretch  
Width: Auto  
Margin: 20  
Gutter: 24

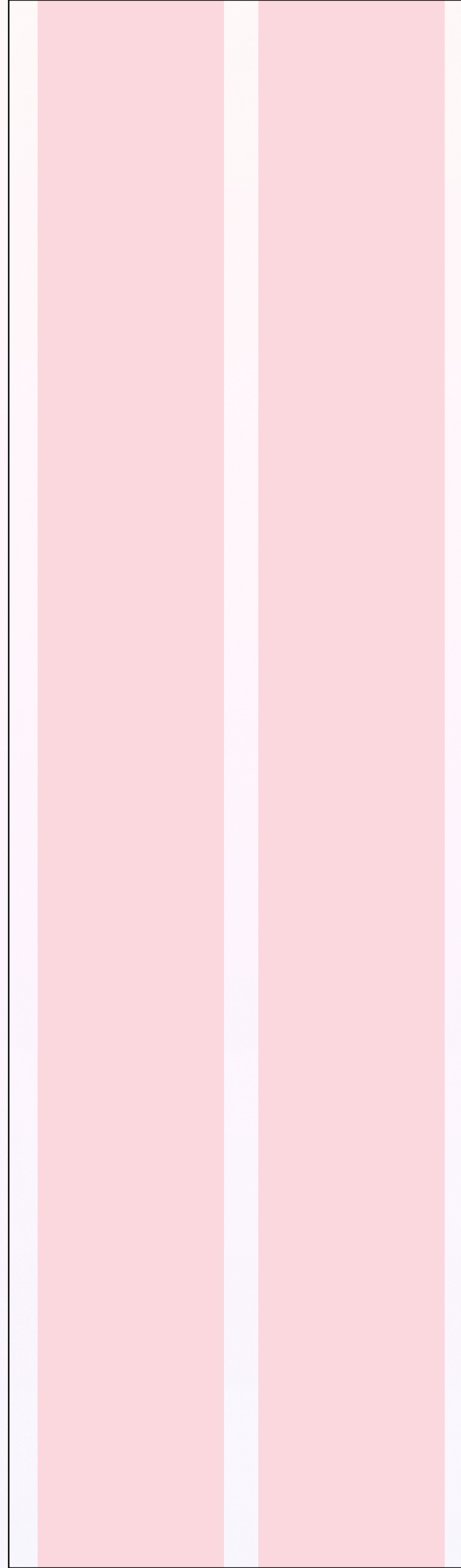

# MEDIUM GRID

## Blue Columns

Count: 2  
Type: Center  
Width: 12  
Offset: 0  
Gutter: 696

## Red Columns

Count: 6  
Type: Stretch  
Width: Auto  
Margin: 36  
Gutter: 24

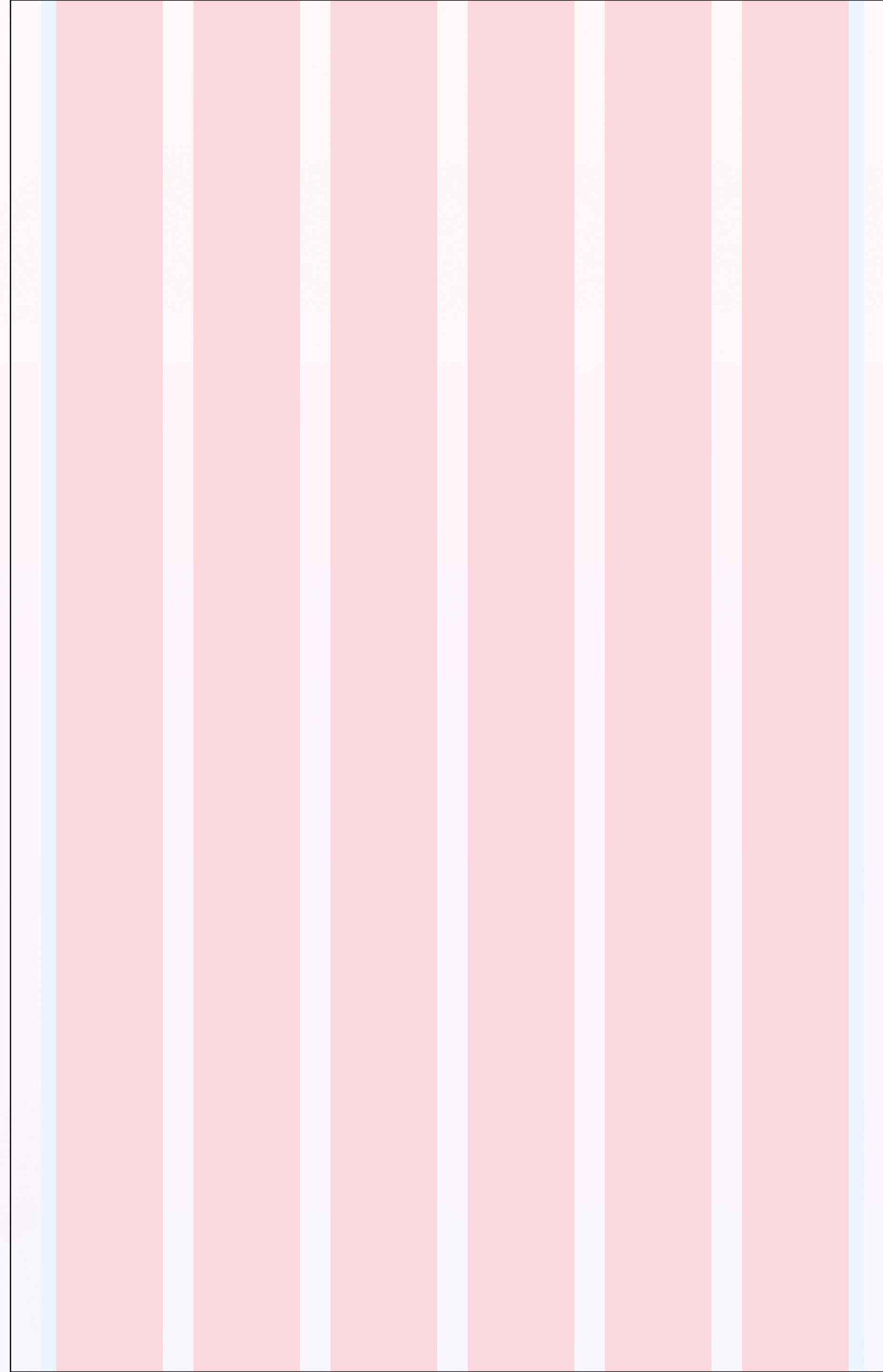

# LARGE GRID

## Blue Columns

Count: 2  
Type: Center  
Width: 12  
Offset: 0  
Gutter: 936

## Red Columns

Count: 12  
Type: Stretch  
Width: Auto  
Margin: 44  
Gutter: 24

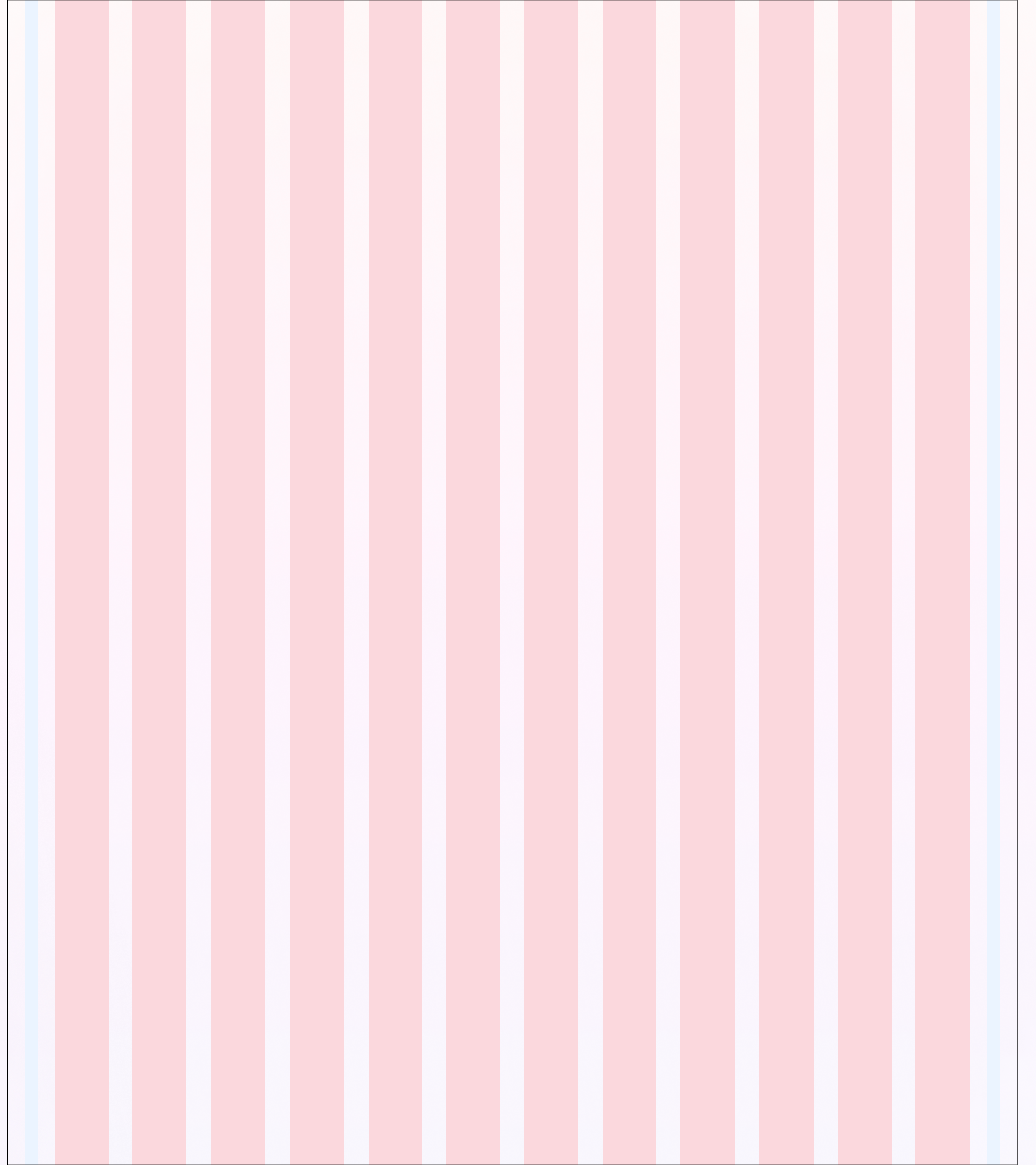

# XLARGE GRID

## Blue Columns

Count: 2  
Type: Center  
Width: 12  
Offset: 0  
Gutter: 1296

## Red Columns

Count: 12  
Type: Center  
Width: 86  
Offset: 0  
Gutter: 24

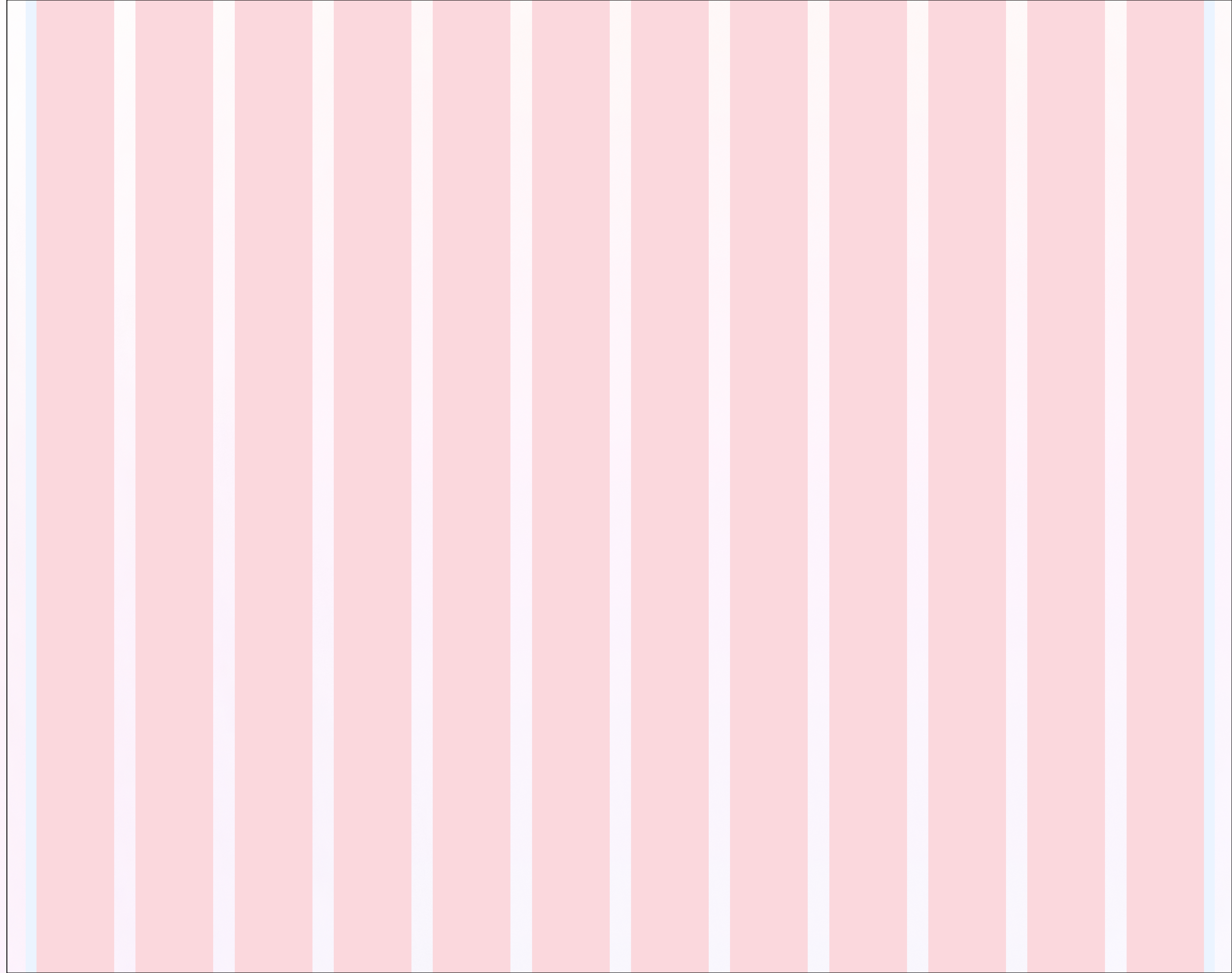

# CTA Buttons

# SIZING

## Desktop

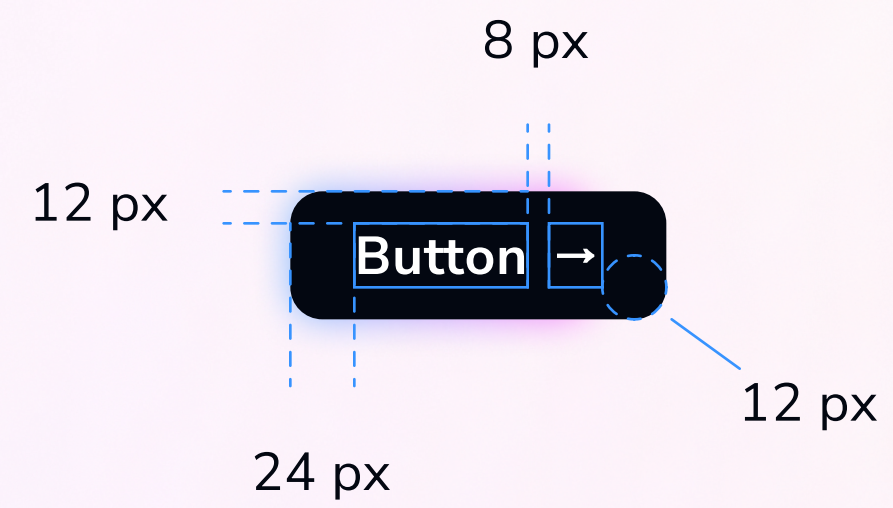

## Mobile

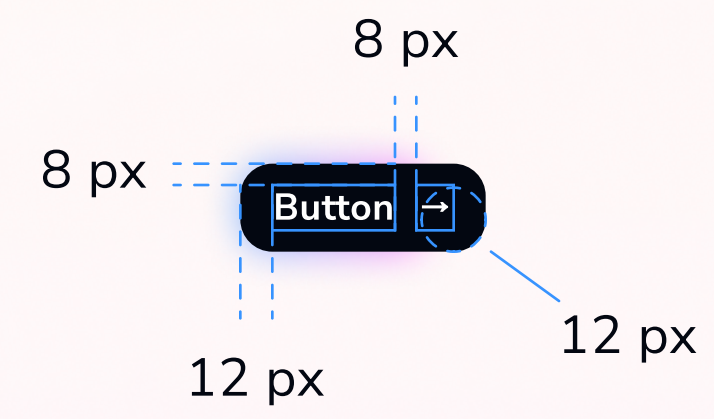

# TYPES

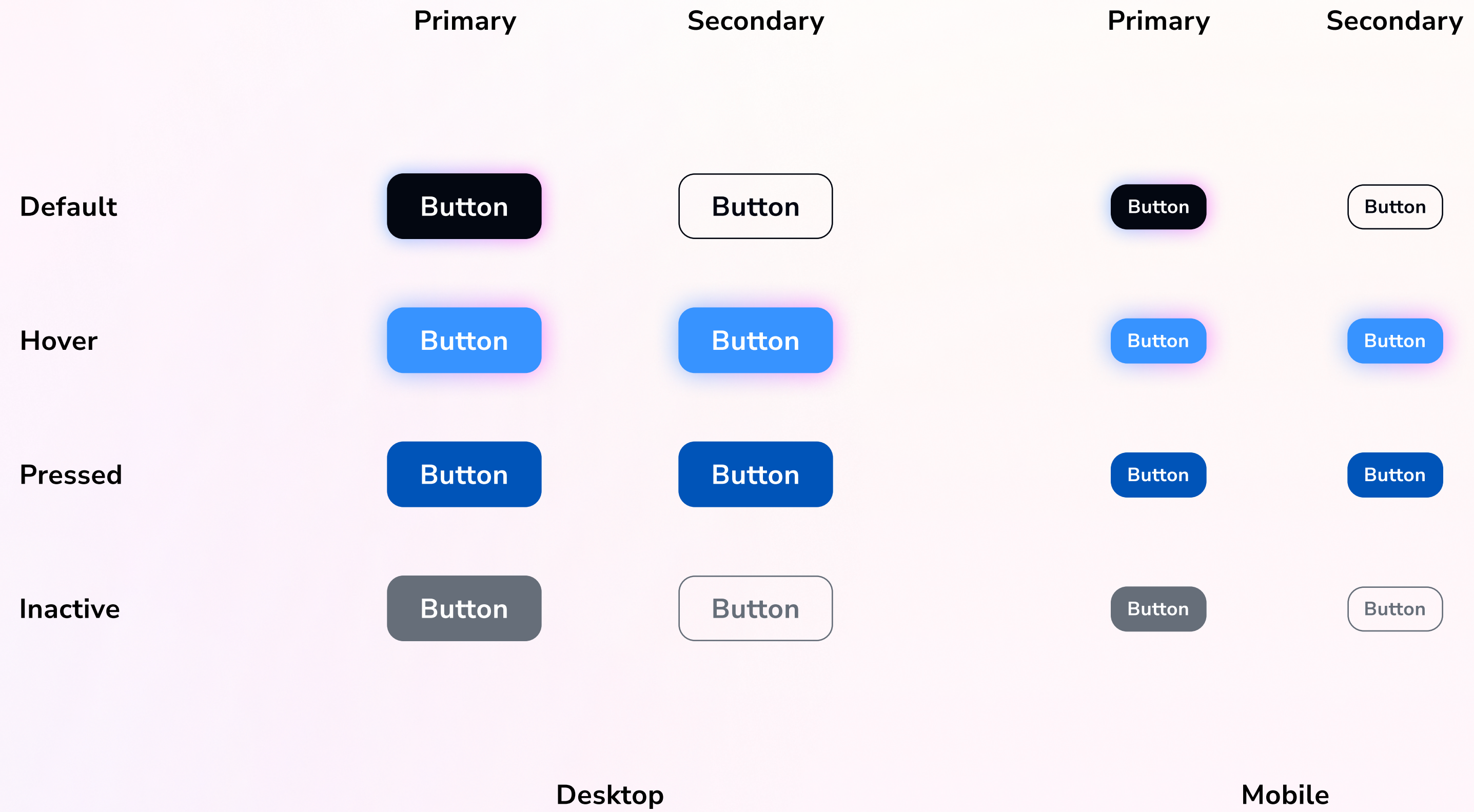

# USAGE

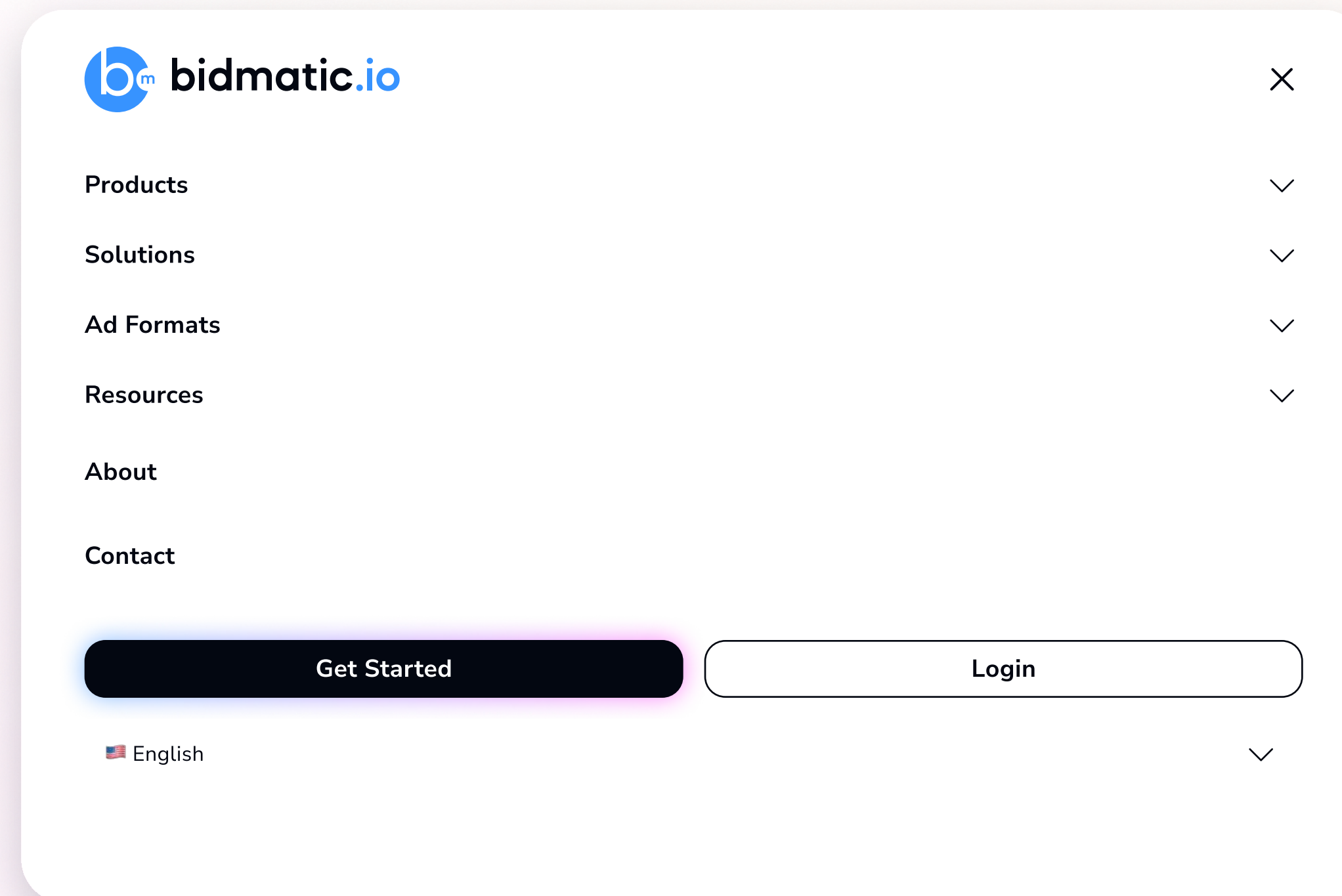
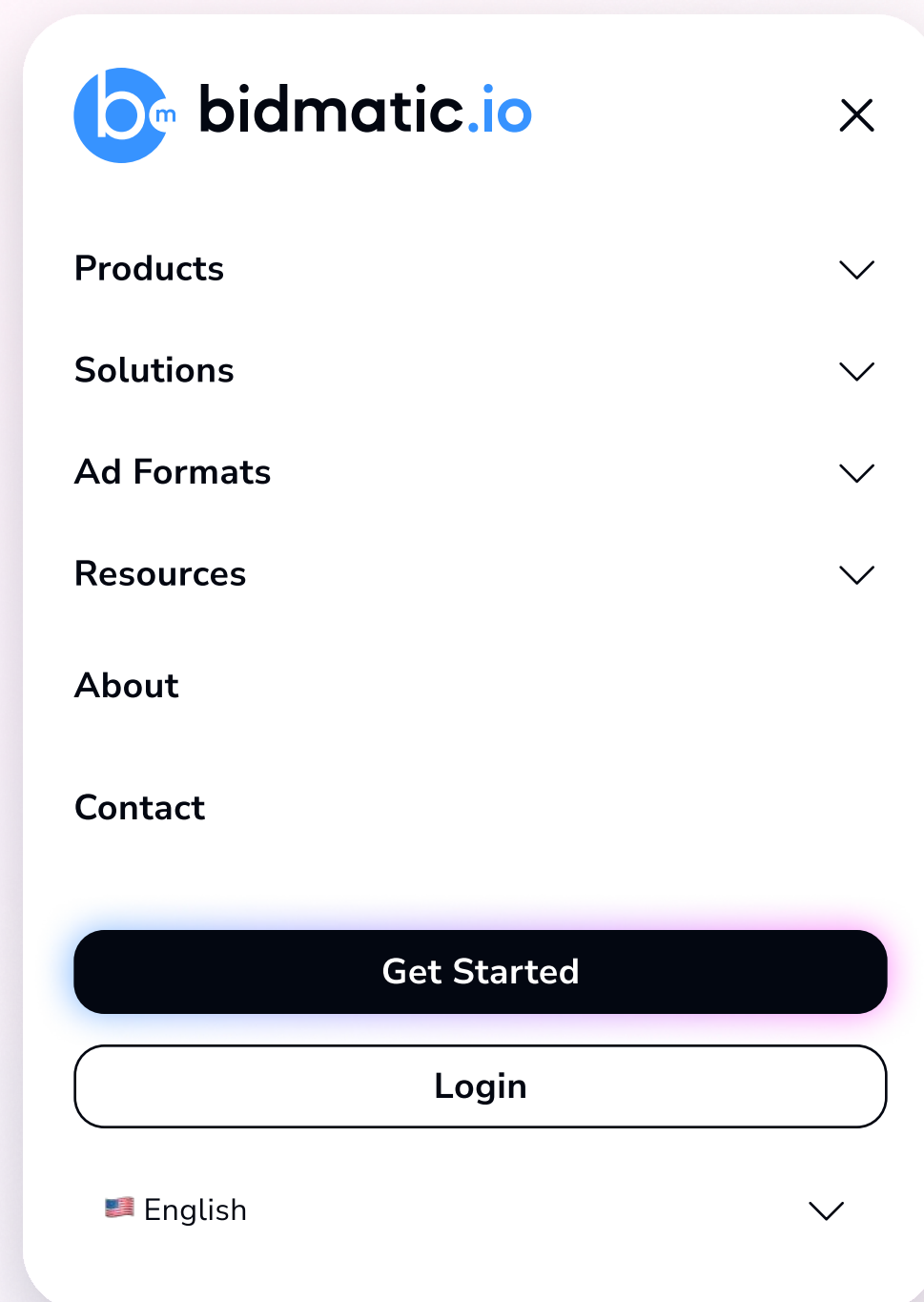

# Imagery

# CORE VISUAL CONCEPT

*“Dynamic Exchange  
Powered by Intelligence.”*

Think of it as a digital marketplace in motion — where AI orchestrates millions of smart decisions every second.

This concept sits at the intersection of:

- Marketplace (many buyers + many sellers)
- Automation (AI-driven bidding)
- Growth & profit (publishers earning more revenue)

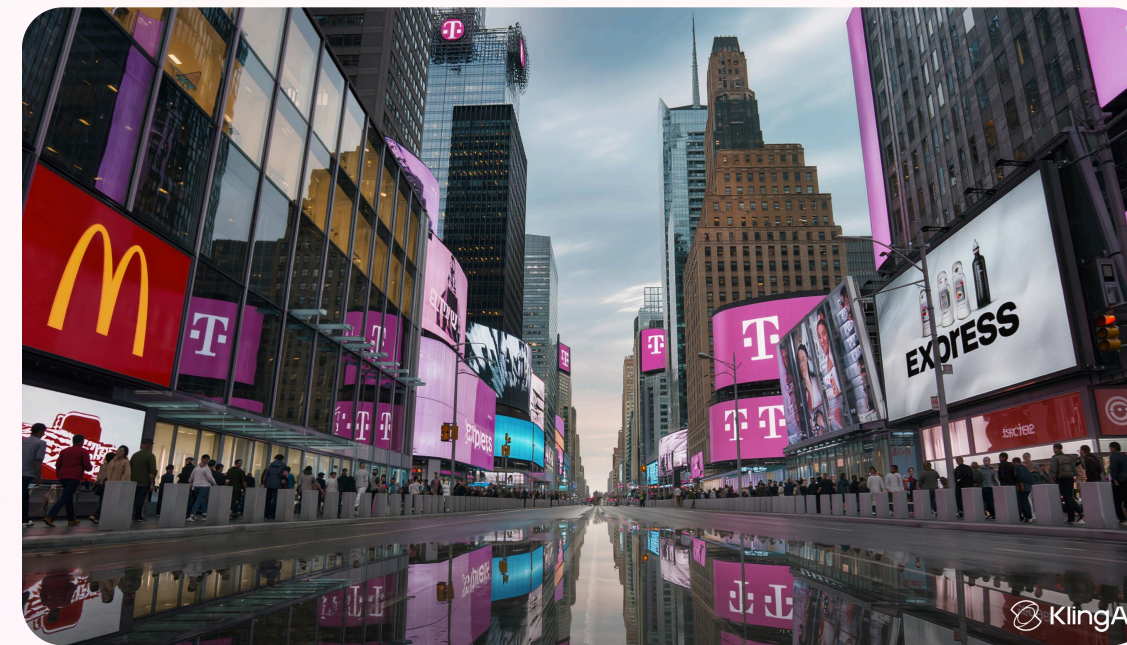

# ADDITIONAL IMAGERY

Use light and shadow to symbolize the valuable, limited and targeted nature of premium advertising space and the clarity that our platform provides.

Position the company as a safe, reputable and reliable intermediary.

Emphasize the company's role in the seamless and intelligent interaction of buyers and sellers, often using advanced technologies (AI, data analytics).

Smart ad placement, without the hassle of connecting.

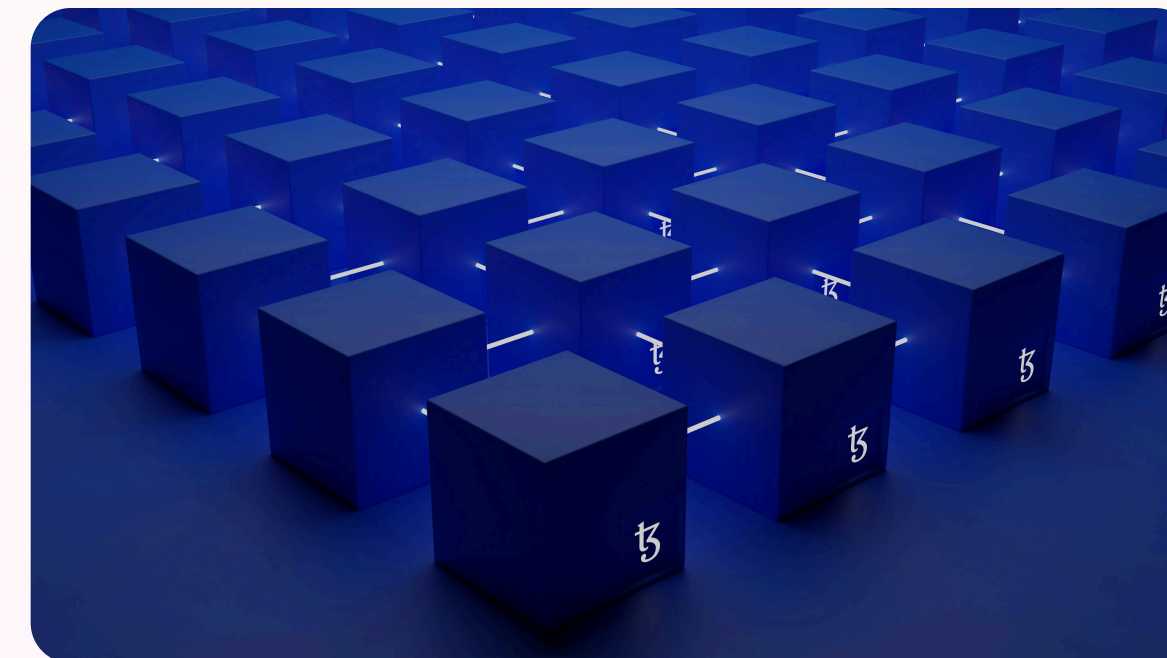
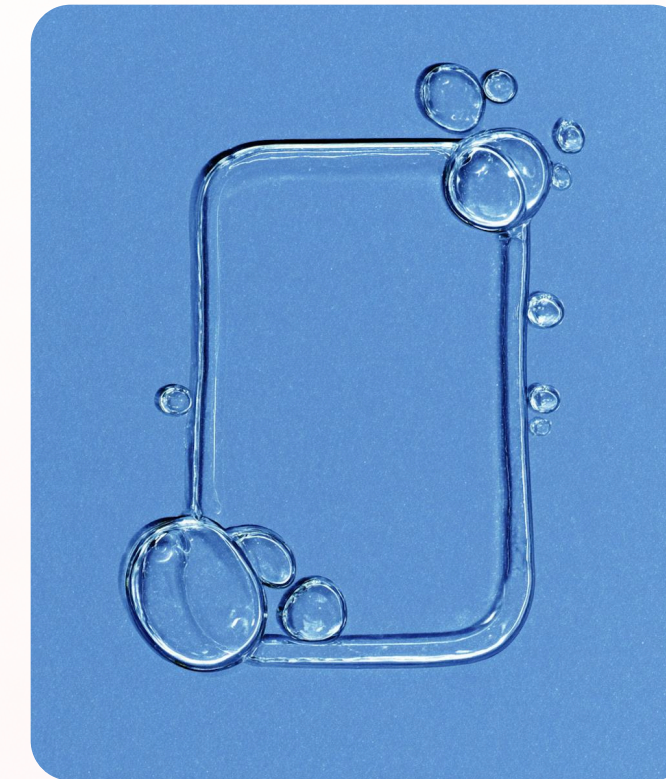

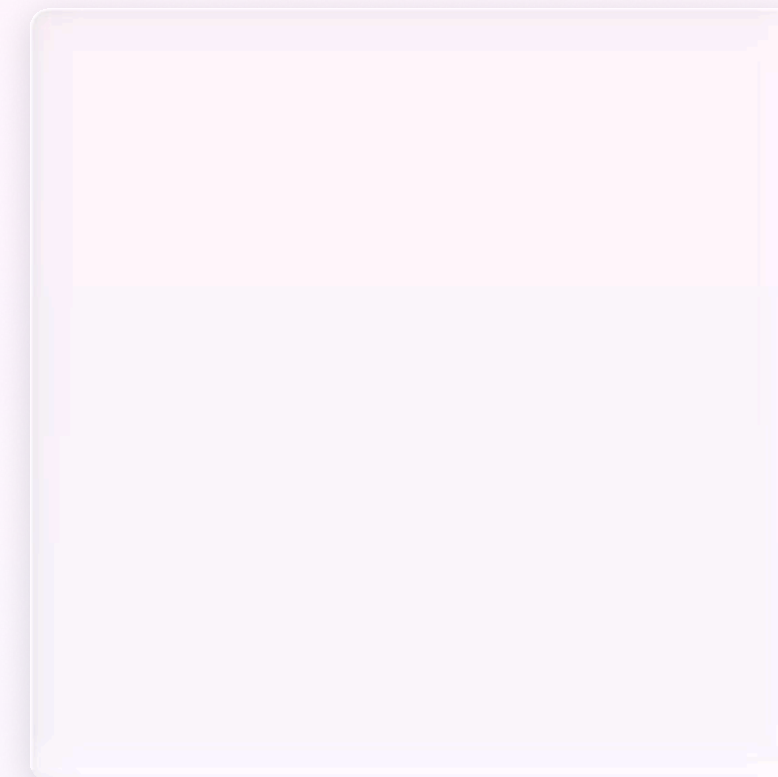
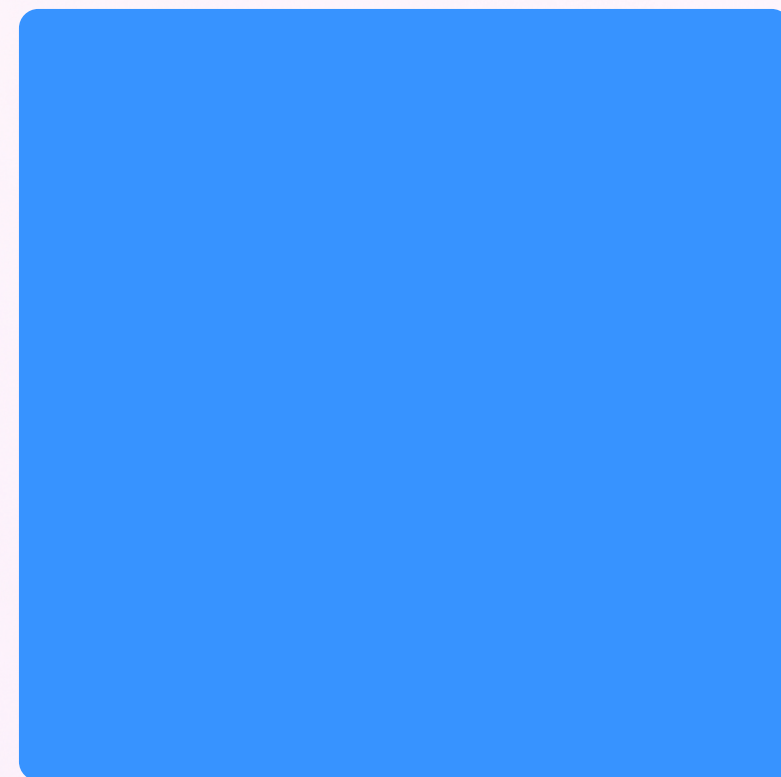
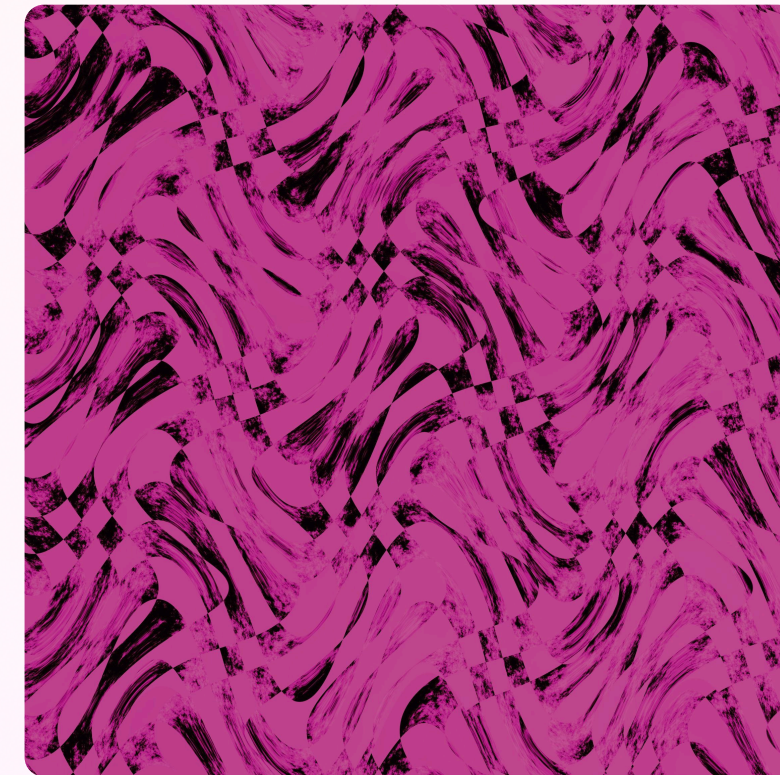
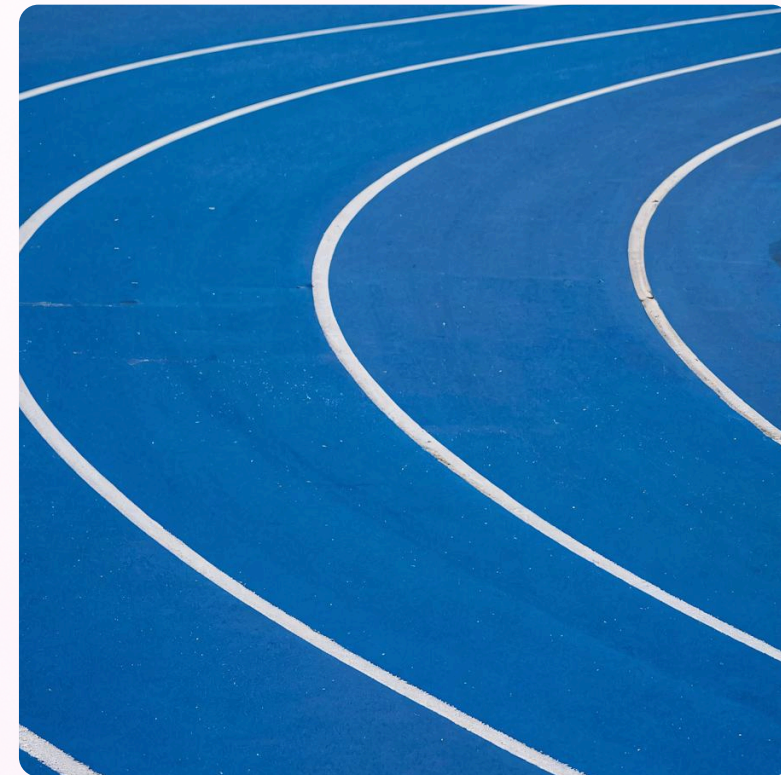
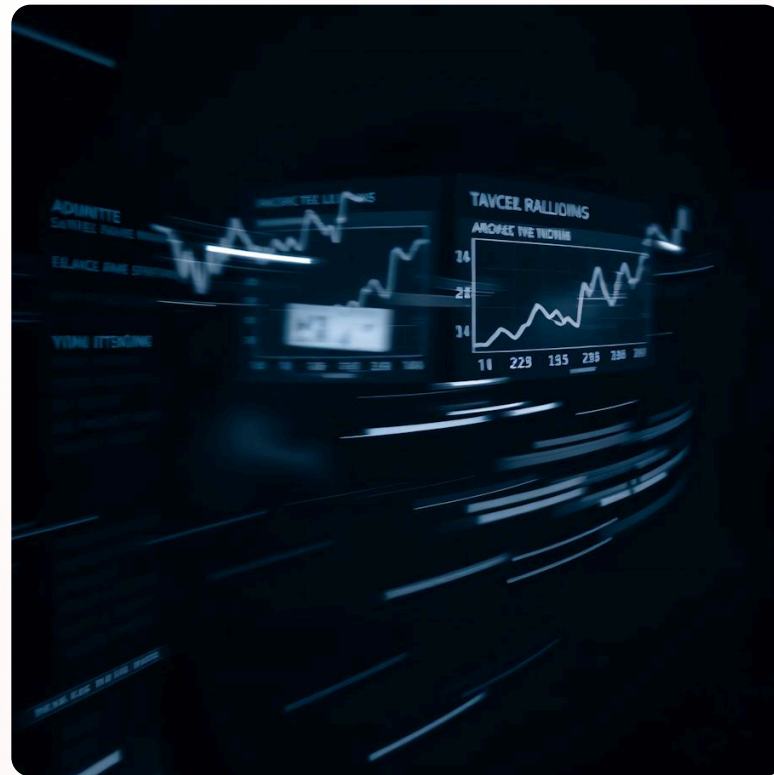

# Essentials

# ICONOGRAPHY STYLE

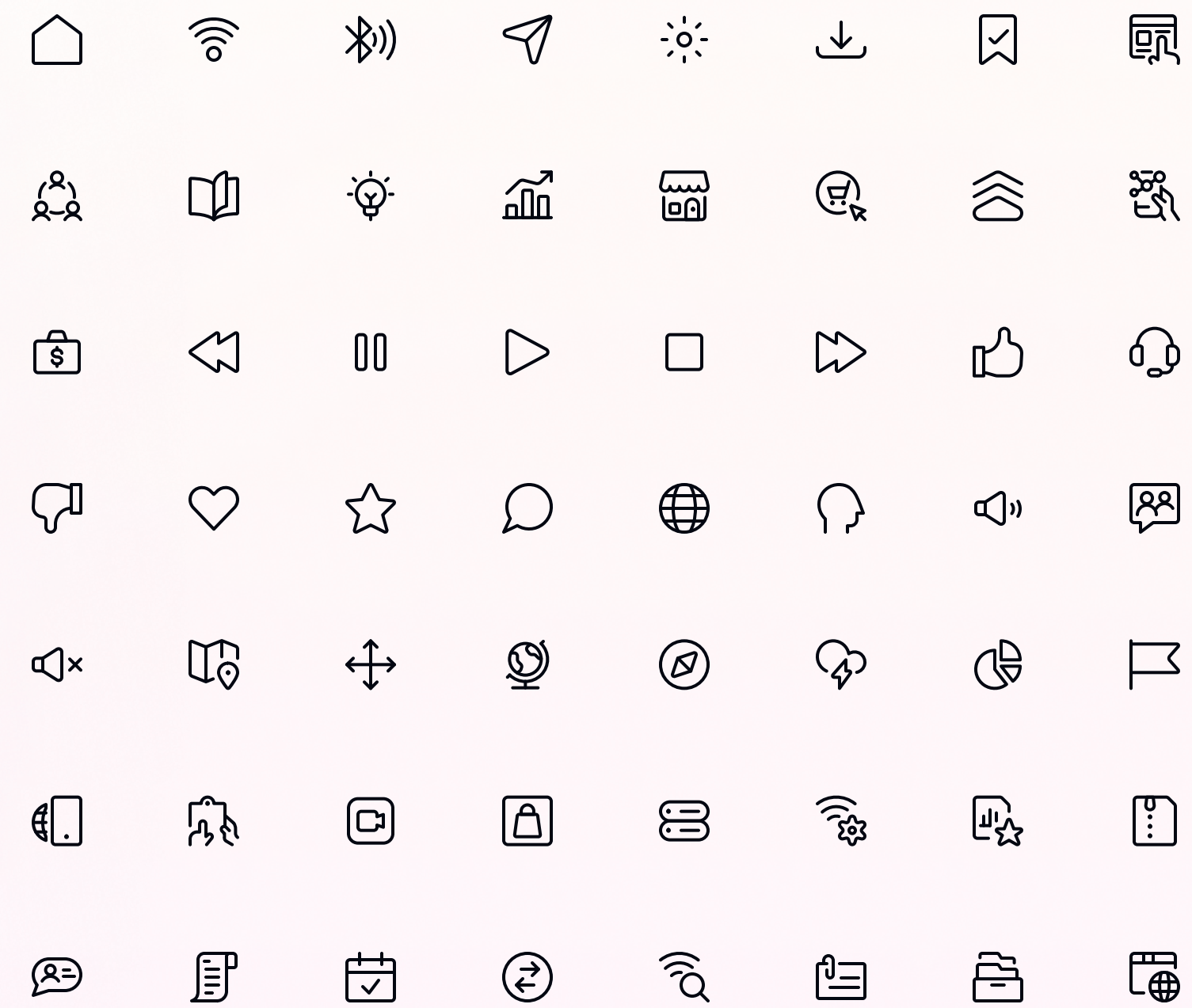

# SPACING

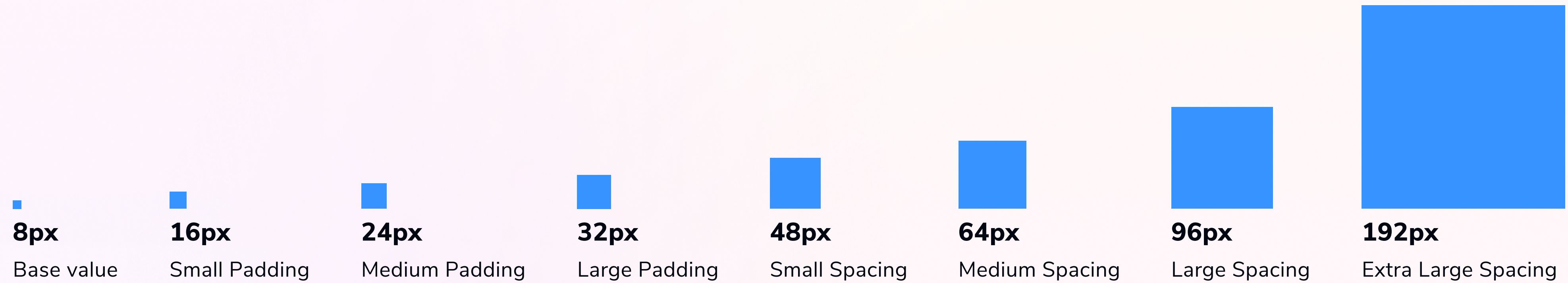

# SHADOWS



Default Black Shadow



Big Black Shadow



Default Blue Shadow



Big Blue Shadow